

This Quick Start Guide provides a general overview for basic installation. For more in-depth information and troubleshooting steps, please refer to the full Operator's Guide for your meter.

INSTALLATION OVERVIEW

1 Install FLEXPoint™ Software

Scan the QR code below or visit:

- www.dentstruments.com/software-downloads
- FLEXPoint is a free tool **required** to configure your PowerScout™ FLEX Series meter.



Step 2: Install and Launch FLEXPoint™ Software

- Once the download is complete:
- Open the installer and follow the prompts.

2 Remove covers & mount

Loosen top cover screws (x4) [Note: Screws are captured in the case.] Remove the High Voltage Cover Screws (x2). [Note: These screws are NOT captured; do not lose.]

Use the enclosure as a template to mark mounting holes

Note: Mechanical specifications and drawings are found in the Operator's Guide.

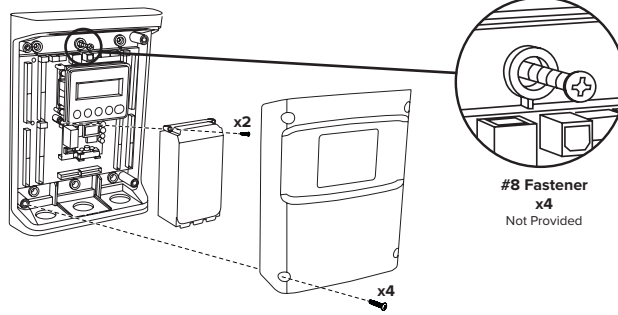

3 Connect

- Attach 1" EMT Conduit fittings (or reducer bushing)
- Attach flexible Conduit
- Plug unused holes with blanking plugs (provided)

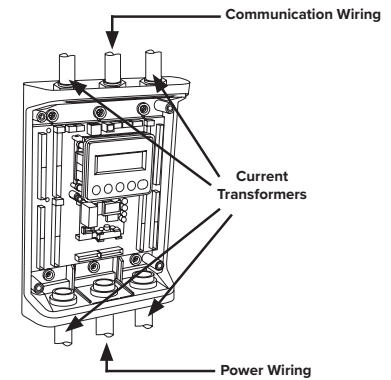

4 Connect AC voltage wires

WARNING: RISK OF ELECTRIC SHOCK. DO NOT ENERGIZE METER WITH VOLTAGE COVER REMOVED. FOLLOW ALL STATE AND FEDERAL ELECTRICAL CODES.

- Using 14 AWG THHN, 600VAC rated wire, connect the voltage leads (L1, L2, L3, and N) as necessary to the meter through a dedicated disconnect or circuit breaker. **DO NOT EXCEED 346V L-N or 600V L-L.**
- Mark the circuit breaker as "PowerScout FLEX Meter"

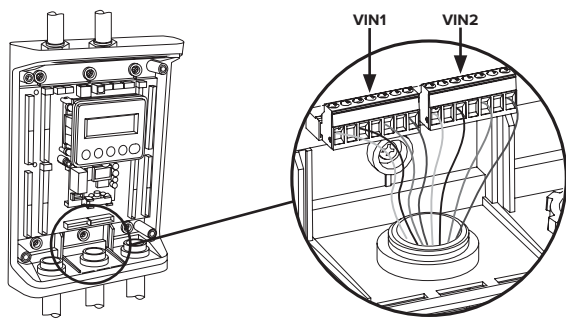

5 Re-attach high voltage cover

Meter is IP30 (TouchSaf™) with internal cover installed.

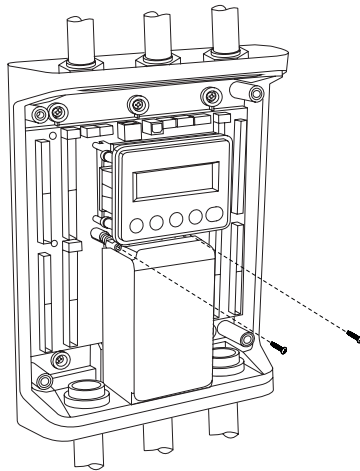

6 Connect CT & communications wiring

Use only 333.3mV (1/3 V) output CTs or DENT RōCoils.

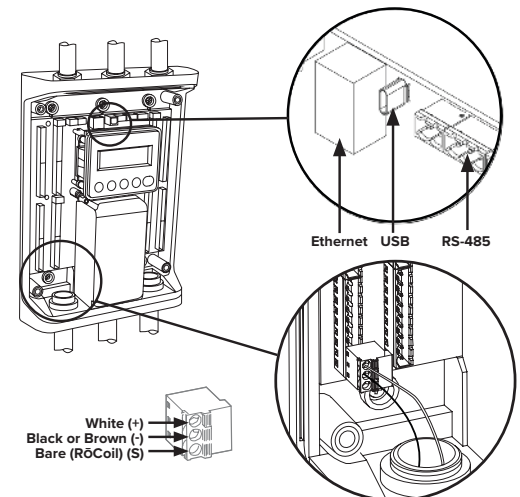

WIRING

HIGH VOLTAGE MAY BE PRESENT. RISK OF ELECTRIC SHOCK. LIFE THREATENING VOLTAGE MAY BE PRESENT. QUALIFIED PERSONNEL ONLY.

These diagrams show the wiring configuration for the Service Types available in the Service drop-down list under "Meter Setup; Service" in FLEXPoint™ Software.

The PowerScout™ FLEX Meter is internally powered through the voltage between L1 and L2. For Single Phase installations, where no L2 exists, connect a jumper from N to L2. This connection provides power to the meter while maintaining Neutral as the metering voltage reference.

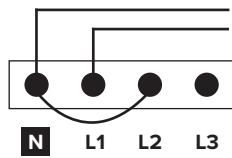

The PowerScout™ FLEX Meter uses the Neutral terminal as a voltage reference. For systems without a neutral conductor, connect a wire from the N terminal to ground.

CONNECTING VOLTAGE WIRING AND CTs TO THE METER

This image shows how to connect CTs to the PowerScout™ FLEX Meter for Three Phase services. For other service types (Single Phase and Split Phase), see the Operator's Guide. Three Phase loads are shown on the left only for illustration and may be used on the right as well. All meter elements are fully configurable and interchangeable.

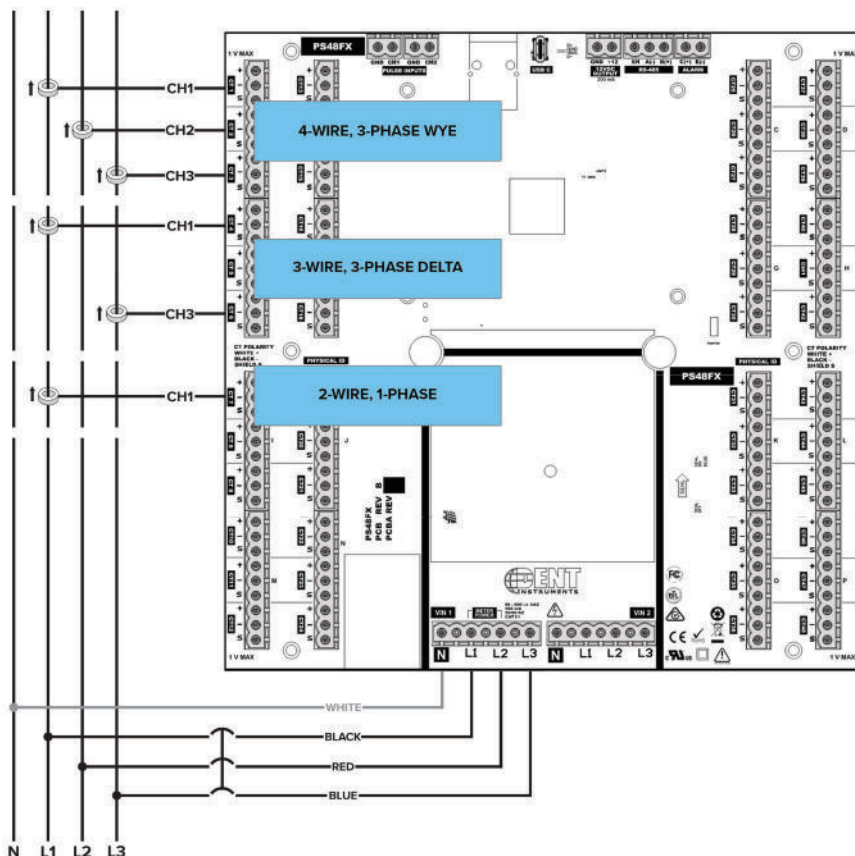

EXAMPLE 1

Wiring the PowerScout™ FLEX in a 3-Wire, Split Phase Service Panel

TYPICAL LOADS:

Single Phase L1-N or L2-N 110 VAC: Lighting, Appliance, or Living Zone

Single Phase L1-L2 220 VAC: Water Heater or Equipment with no Neutral wire.

Split Phase L1-L2 220 VAC: Service Entrance, Dryers, or Equipment with Neutral wire.

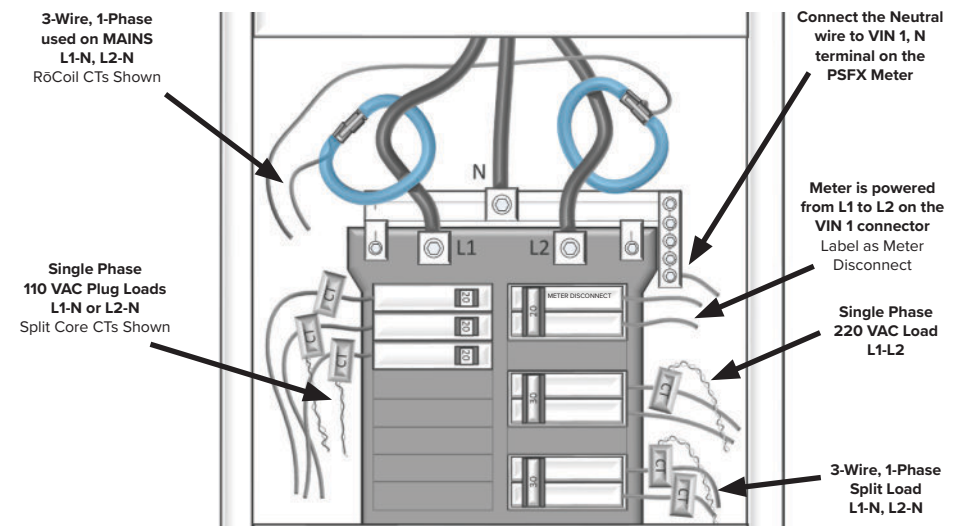

EXAMPLE 2

Wiring the PowerScout™ FLEX in a 4-Wire, 3-Phase Service Panel

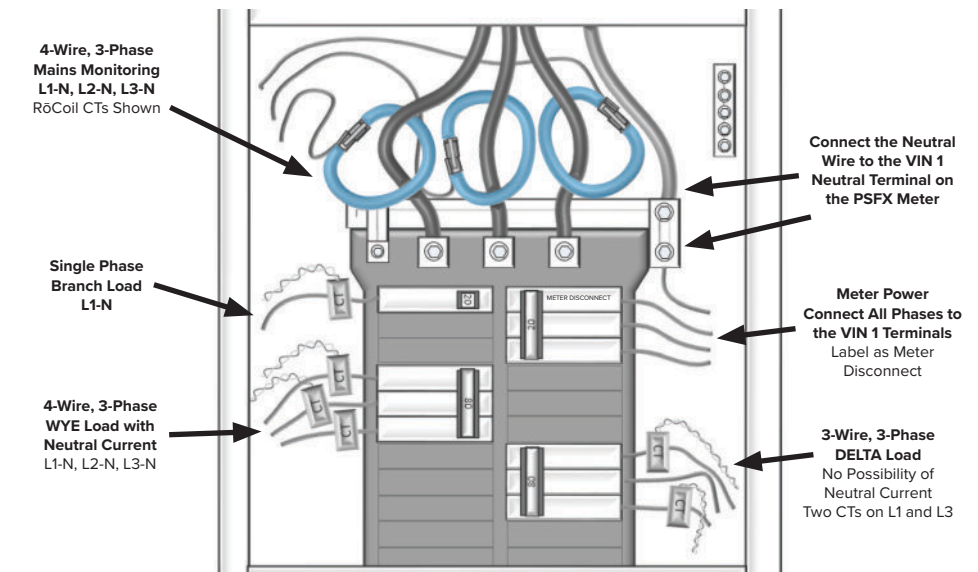

SETUP THE METER WITH A PC

1. Connect a powered, or unpowered, PowerScout™ FLEX meter to a USB port of your computer with a USB A to USB B cable (provided). [Note: The PC will power the meter for setup even without AC mains power connected.]
2. Launch the FLEXPPoint™ application and, when prompted, click “Connect over USB”
3. The meter will now be communicating with the PC
4. Use FLEXPPoint software to configure the meter and view real-time data to verify the installation is wired correctly
5. Follow the instructions below to install the FLEXPPoint™ software

 The meter can also be setup without using FLEXPPoint™ Go software and instead using a web browser. Plug in the USB cable and set the browser to **169.254.1.5**.

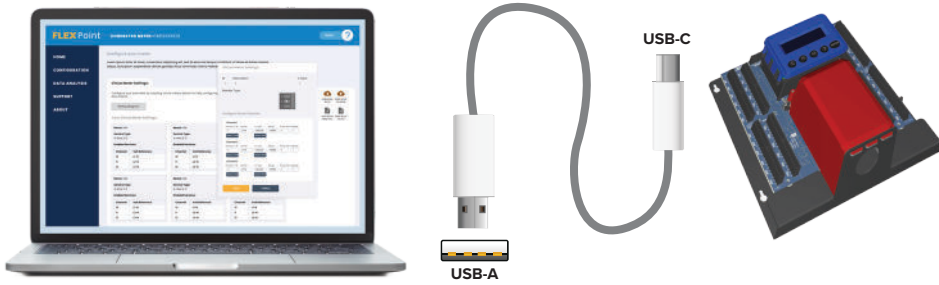

NAVIGATING THE METER'S DISPLAY

VIEW COMMUNICATIONS	→	PROTOCOL: BACNET
REAL-TIME VALUES	→	BAUD RATE: 9600
VIEW METER SETUP	←	BITS: 8N1
VERIFY INSTALLATION		
LOG IN / OUT		
ABOUT METER		

VIEW COMMUNICATIONS	↕		↕	
REAL-TIME VALUES	↕	ELEMENT A CHANNELS	↕	ELEMENT A CHANNELS
VIEW METER SETUP	↕	V 100 101 99.9	↕	KVA 100 110 111
VERIFY INSTALLATION	↕	A 23.2 22.9 22.0	↕	KVAR 100 -110 123
LOG IN / OUT	↕	KW 2.0 2.0 2.0	↕	KWH 1234 *** 100
ABOUT METER	↕		↕	

USING THE LCD SCREEN





Use the arrow keys to move from one menu display to the next. The ENTER button is used to make a change. Note that changes to the meter configuration are limited to the communication interface when using the LCD. If additional changes (such as CT type) are required, they must be made using either FLEXPPoint™ software or web server interface.

FOR MORE INFORMATION



- www.DENTinstruments.com
- 1.800.388.0770
- support@DENTinstruments.com



SAFETY SYMBOLS

-  DENOTES HIGH VOLTAGE. RISK OF ELECTRIC SHOCK. LIFE THREATENING VOLTAGES MAY BE PRESENT. QUALIFIED PERSONNEL ONLY.
-  Denotes caution. See full Operator's Guide for description of the meanings.
-  Equipment protected throughout by double insulation or reinforced insulation.
-  Contains additional information pertinent to the current subject.

WARNING

-  **DO NOT EXCEED 346V Line-to-Neutral or 600V Line-to-Line. This meter is equipped to monitor loads up to 346V L-N. Exceeding this voltage will cause damage to the meter and danger to the user. Always use a Potential Transformer (PT) for voltages in excess of 346V L-N or 600V L-L. The PowerScout™ FLEX is a 600 Volt Over Voltage Category III device.**
-  RISK OF ELECTRIC SHOCK, EXPLOSION, OR ARC FLASH. CAREFULLY READ AND FOLLOW INSTRUCTIONS.
- THIS METER MAY CONTAIN LIFE THREATENING VOLTAGES. RISK OF ELECTRIC SHOCK. QUALIFIED PERSONNEL ONLY. USER MUST DISCONNECT ALL HIGH VOLTAGE WIRING BEFORE SERVICING THE METER WITH THE HIGH VOLTAGE COVER REMOVED.
- TO AVOID FIRE, SHOCK, OR DEATH, TURN OFF ALL POWER SUPPLYING EQUIPMENT BEFORE WORKING ON OR INSIDE THE EQUIPMENT. USE PROPERLY RATED VOLTAGE SENSING DEVICE TO CONFIRM POWER IS OFF.
- FOLLOW SAFE ELECTRICAL WORK PRACTICES. FOLLOW ALL APPLICABLE LOCAL ELECTRICAL CODES.
- THIS EQUIPMENT MUST BE INSTALLED AND SERVICED BY QUALIFIED ELECTRICAL PERSONNEL WITH THE REQUISITE KNOWLEDGE, TRAINING, AND EXPERIENCE RELATED TO THE INSTALLATION AND OPERATION OF THIS EQUIPMENT.
- PRODUCT MAY USE MULTIPLE VOLTAGE/POWER SOURCES. BE SURE ALL SOURCES OF POWER HAVE BEEN DISCONNECTED BEFORE SERVICING.
- DO NOT DEPEND ON THIS PRODUCT FOR VOLTAGE INDICATION.

CURRENT TRANSFORMER BASICS

To ensure safety and maintain UL listings, use only CTs provided by DENT Instruments.

- Do not use on services greater than 600VAC
- CTs are 333.3 mV (1/3 V) output voltage, or DENT R6Coil
- Select CTs of appropriate current range for the circuit (5-120% of CT rating recommended)
- Ensure arrow points towards load (or as instructed by CT label)
- Place CT on first conductor of voltage reference. Example: for L1-L2 circuits without neutral, place CT on L1
- Observe wiring color and polarity: For millivolt CTs, the white wire is (+) and the black wire is (-). For R6Coils, the white is (+), brown is (-), and the bare, shield wire connects to the terminal marked “S”

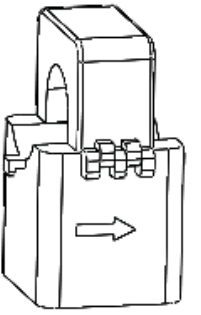

POWERSCOUT™ FLEX 12

- | | | |
|------------------|------------------------------------|-------------------------------|
| 1. Alarm Output | 7. Display | 12. CT Inputs (12 total) |
| 2. Ethernet | 8. Navigation Buttons | 13. High Voltage Cover (IP30) |
| 3. USB | 9. Voltage Connection | 14. Mounting Plate |
| 4. RS-485 | 10. 1" EMT Conduit Connection (x5) | 15. ABS Plastic Enclosure |
| 5. 12V Out (2W) | 11. Pulse Inputs (4 total) | |
| 6. Mounting Hole | | |

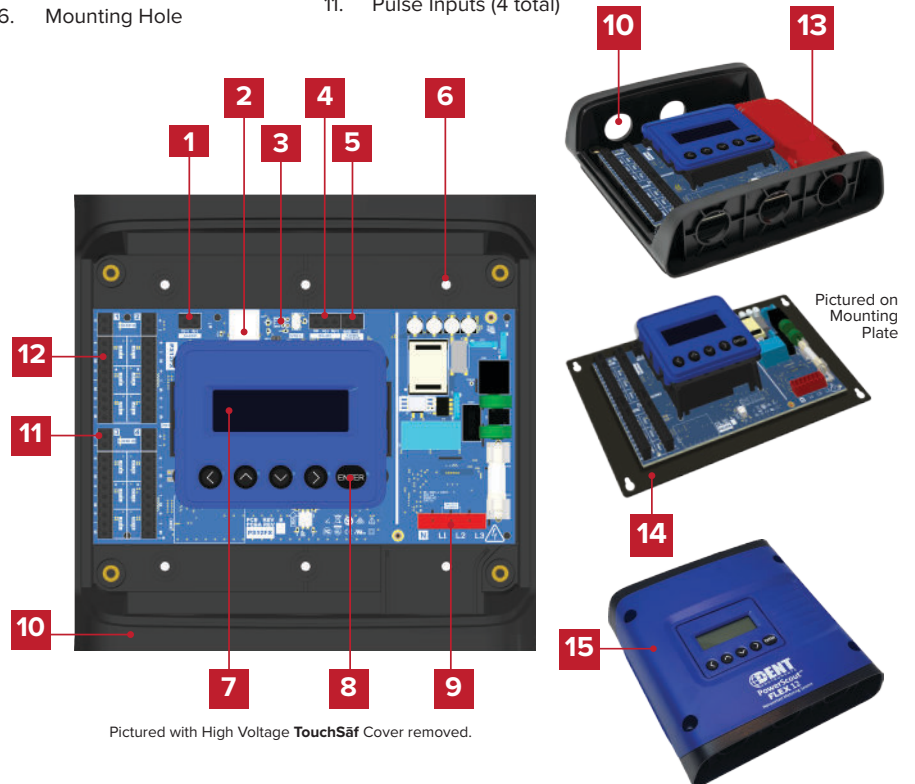

POWERSCOUT™ FLEX 24/48

- | | | |
|------------------|-------------------------|------------------------------------|
| 1. Pulse Input 1 | 7. Alarm Output | 13. Mounting Plate (Optional) |
| 2. Pulse Input 2 | 8. CT Inputs (24 or 48) | 14. High Voltage Cover (IP30) |
| 3. Ethernet | 9. Display | 15. 1" EMT Conduit Connection (x6) |
| 4. USB | 10. Navigation Buttons | 16. ABS Plastic Enclosure |
| 5. 12V Out (2W) | 11. Voltage Input 1 | |
| 6. RS-485 | 12. Voltage Input 2 | |

